

LHS 21: Designed for professionals.

These advanced air heaters are distinguished by their extremely small dimensions – especially the lean design (only 67 mm wide) – as well as their long service life. Designed for professional integration in machine systems, the new LHS series enables any specific application. Sterilization, drying, welding, cleaning, shrinking, shaping, deburring and activation are now more efficient and reliable thanks to Leister's proven hot air technology!

Air heater

LHS 21



Technical data

Max. air outlet temperature	°C	650
Max. air inlet temperature	°C	65
Max. ambient temperature	°C	80
Min. airflow		As per diagram page 31
Relative humidity	%	5 – 95 non condensing
Max. inlet pressure	kPa	100
Weight 21S / 21L	kg	0.55 / 0.65
Conformity mark		CE
Protection class II		□

Installation dimensions in mm

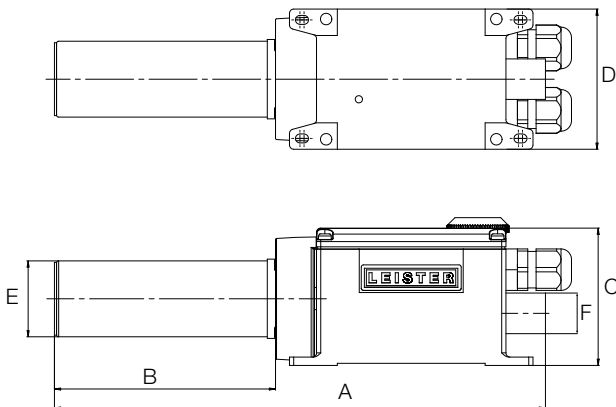

Typ	A	B	C	D	E	F
LHS 21S	236	106	66	67	∅ 36	∅ 19.5 G 3/8"
LHS 21L	266	136	66	67	∅ 36	∅ 19.5 G 3/8"

Combination possibilities

- Leister air heater at maximum heat power and without nozzle with Leister blower at 50 Hz, 1.5 m hose length and unimpeded air outflow.
- Hot air temperature 3 mm after air outlet, measured at the hottest point.
- Air flow at 0°C, 101.3 kPa compliant with DIN 1343.

Blower Type	Number LHS 21S x Power consumption kW	LHS 21S x Air flow l/min.	LHS 21S Temperature °C
ROBUST	1 x 1.0	1 x 640	160
ROBUST	2 x 1.0	2 x 420	200
ROBUST	4 x 1.0	4 x 240	300
ROBUST	1 x 2.0	1 x 590	300
ROBUST	2 x 2.0	2 x 390	380
ROBUST	4 x 2.0	4 x 220	540
MONO	2 x 1.0	2 x 341	236
MONO	1 x 2.0	1 x 525	333
MONO	2 x 2.0	2 x 353	450

Blower Type	Number LHS 21L x Power consumption kW	LHS 21L x Air flow l/min.	LHS 21L Temperature °C
ROBUST	1 x 3.3	1 x 550	520
ROBUST	2 x 3.3	2 x 390	610
AIRPACK	2 x 3.3	2 x 1210	270
AIRPACK	4 x 3.3	4 x 700	340
MONO	1 x 3.3	1 x 430	610

Air flow and temperature values may deviate from those above based on the design of the entire hot air system (including nozzles, air hoses, environmental conditions).

High end air heaters on an indexing table for producing light bulbs.



Air heater

LHS 21 CLASSIC



Heating power not adjustable

Detection of heating element and device overheating with alarm output

Air heater

LHS 21 PREMIUM



Heating power steplessly adjustable with potentiometer

Protection against heating element and device overheating with alarm output

Air heater

LHS 21 SYSTEM



Heating power or temperature steplessly adjustable with potentiometer or remote control interface

Protection against heating element and device overheating with alarm output

Remote control interface for external temperature controllers (Leister CSS, or PLC's)

Air Heaters
Controllers

Order no.:

		CLASSIC	PREMIUM	SYSTEM
LHS 21S	1.0 kW/120V	139.868	140.454	140.458
LHS 21S	1.0 kW/230V	139.869	140.455	140.459
LHS 21S	2.0 kW/120V	139.870	140.456	140.460
LHS 21S	2.0 kW/230V	139.871	139.909	139.910
LHS 21L	3.3 kW/230V	139.872	140.457	140.461

Contact a Leister sales partner in your region for professional advice and information on our other air heaters and blowers.

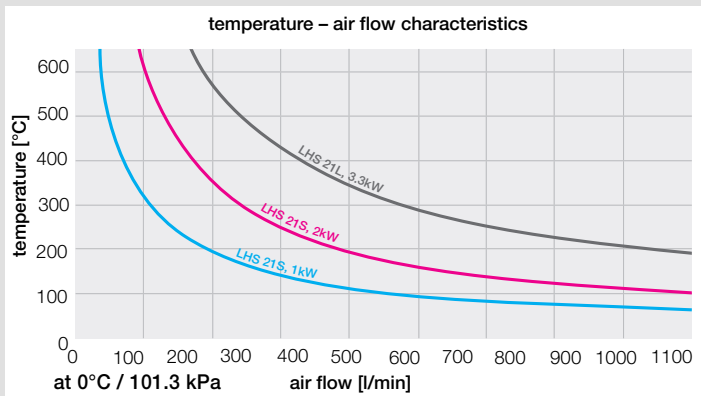

Air heater and blower for drying labels. Fast drying allows for high throughput speeds.



Accessories LHS 21 and LE 3000 (Ø 36.5 mm)

107.261 108.078 105.982		Wide slot nozzle, push-fit (a × b) 70 × 4 mm 100 × 4 mm 150 × 4 mm
107.308 107.309		Sieve reflector, push-fit (a × b) 35 × 50 mm 20 × 35 mm
107.314		Spoon reflector, push-fit (a × b) 25 × 30 mm
107.319		Sieve reflector, push-fit Ø 65 mm
106.132		Shell reflector, push-fit (a × b) 150 × 25 mm
144.037		Compressed air connection > LHS 21
143.480		Adapter plates LHS 21 instead LE 3000 > LHS 21
142.230		Adapter plates LHS 21 instead LHS 20 > LHS 21
144.030 144.028 144.026		System Interface cable 1 m 3 m 5 m one end single wires, one end RJ45
133.515		Thermo couple holder